

Optimizing Smart Energy Control Strategies for Plug-In Hybrid Electric Vehicle Charging

Kevin Mets, Tom Verschueren, Wouter Haerick, Chris Develder and Filip De Turck

Dept. of Information Technology – IBCN

Faculty of applied sciences

Ghent University – IBBT

G. Crommenlaan 8 Blok C0 Bus 201

9050 Ghent, Belgium

Email: {kevin.mets, tom.verschueren, wouter.haerick, chris.develder, filip.deturck}@intec.ugent.be

Abstract—The electrification of the vehicle fleet will result in an additional load on the power grid. Adequately dealing with such pluggable (hybrid) electrical vehicles (PHEV) forms part of the challenges and opportunities in the evolution towards Smart Grids. In this paper, we investigate the potential benefits of using control mechanisms, that could be offered by a Home Energy control box, in optimizing energy consumption stemming from PHEV charging in a residential use case. We present smart energy control strategies based on quadratic programming for charging PHEVs, aiming to minimize the peak load and flatten the overall load profile.

We compare two strategies, and benchmark them against a business-as-usual scenario assuming full charging starting upon plugging in the PHEV. The first, local strategy only uses information at the home where the PHEV is charged: as a result the charging is optimized for local loads. The local strategy is compared to a global iterative strategy which controls the charging of multiple vehicles based on global load information over a residential area. Both strategies control the duration and rate of charging and result in charging schedules for each vehicle. We present quantitative simulation results over a set of 150 homes, and discuss the strategies in terms of complexity and performance (esp. resulting energy consumption), as well as their requirements concerning infrastructure and communication.

I. INTRODUCTION

The electrification of the vehicle fleet will result in an additional load on the power grid that originates from the need to recharge the batteries of PHEVs. Adequately dealing with such pluggable (hybrid) electrical vehicles (PHEV) forms part of the challenges and opportunities in the evolution towards Smart Grids.

The current power grid infrastructure has enough spare generating capacity to support PHEV penetration levels ranging from 30% to 70% when being considered at large scale (e.g. nation wide) [1]. This spare generating capacity however is mostly available during off-peak moments such as night time. Hence, there is an opportunity to limit the extra electricity required to satisfy the PHEV charging demand by shifting them in time.

To make optimal use of this spare generating capacity, we need control mechanisms that achieve shifting the resulting charger loads to times at which spare generating capacity is available.

Uncontrolled charging of PHEVs can also lead to local problems in the distribution grid, for example power losses, which can be lowered by flattening the peak load as a result of controlling the charging process of PHEVs [2].

An automated control method is preferred and can be made possible by integrating energy control strategies in for example a Home Energy Control Box or a Smart Charger.

In this paper, we first determine the amount and distribution of the additional load resulting from PHEV charging in a business-as-usual (BAU) scenario in which we assume that the charging happens at a fixed rate and starts when a vehicle arrives at home. There is no control or coordination in this scenario. This BAU case will serve as benchmark to estimate the potential advantages of two control strategies optimizing energy consumption resulting from PHEV charging. The goal of these energy control strategies will be to minimize the peak load and flatten the overall load profile.

The first strategy is a local energy control strategy, which controls the charging process of a single vehicle and is based on load information from the home at which the vehicle is charging. The second strategy is an iterative global energy control strategy, which is based on global load information that includes other homes and vehicles.

We investigate the potential benefits of the three energy control strategies based on quantitative simulation results over 150 homes and varying levels of PHEV penetration and discuss the strategies in terms of complexity and performance, as well as requirements concerning infrastructure and communication.

A. Related Work

Several opportunities and limitations concerning the integration of PHEVs with the power grid and renewable energy resources are identified in [3] which presents control methods for charging PHEVs. One of these methods is based on global load information that is being communicated by means of a load signal. The preliminary results suggest that a energy control strategy based on load information offers benefits, especially by avoiding the need for additional generating capacity which results from additional peak load.

The control methods discussed in this paper are also based on load information and take two different approaches. We

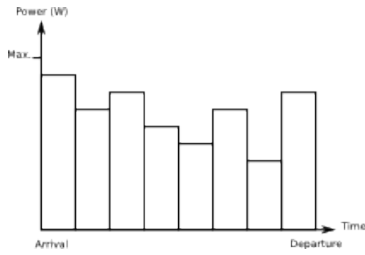

Fig. 1. An illustrative example of a charging schedule.

present a local energy control strategy, which aims at minimizing the peak load and flattening the global load profile, but only requires local load information and no communication. This local control method is compared to a global strategy in terms of complexity, performance and requirements.

As mentioned earlier, the importance of energy control methods which lower peak loads is presented in [2]. Voltage deviations and power losses can occur as a result of charging PHEVs. Flattening peak loads is an effective method to avoid these negative effects.

Research related to PHEVs is not only limited to charging scenarios, but is also targetted at PHEVs providing energy to the power grid, which is known as Vehicle-to-Grid (V2G) [4]. Although control methods are also required for such opportunities, we will focus on optimizing the load resulting from charging PHEVs.

Overall we can conclude that there exists a need for control methods that are responsible for the management of PHEVs.

II. APPROACH

The two energy control strategies we present in this paper control the duration and rate of charging and result in charging schedules for each vehicle. They depend on current and future load information to determine these charging schedules. An illustrative example of a charging schedule is given in Fig. 1. The time between arrival and departure is divided in equal intervals and for each interval the charging schedule defines the charging rate. Both energy control strategies aim to minimize and flatten the overall load profile by controlling the charging process of PHEVs.

The first objective of the energy control strategies is to minimize the peak load of the overall load profile. This is achieved by shifting the energy demand of the PHEVs to times where the energy demand is low. The second objective is to flatten the overall load profile which is realized by not only shifting the charging demand in time, but also controlling the intensity of it, i.e. the rate at which we charge the PHEV battery.

A. Minimizing peak load and valley filling

We characterize the local residential load by two components: the load resulting from charging electric vehicles and a base load which represents the other electric appliances present in the home. We assume those appliances have no flexibility in usage time or power consumption; the base load profile

can not be changed. Indeed, the major concern of this paper is to assess the usefulness of smart energy approaches (based on e.g. a Home Energy Management box at the consumer's premises) in limiting the (peak) loads potentially caused by PHEV charging.

In a business-as-usual scenario, without any intelligent control strategy, charging PHEVs can add additional load to existing peak loads (when charging coincides with these peak loads). If we assume the latter base load to be inflexible, we cannot lower it. PHEVs in contrast do offer flexibility as they are often stationary for prolonged periods. On the other hand, additional loads resulting from charging PHEVs could also create new peak loads if we simply shift them in time.

Shifting energy demand of PHEVs to times at which energy demand is low avoids enlarging existing peak loads or creating new ones. Times at which energy demand is low are characterized by valleys in the load profile. These valleys will be filled and the load profile will level as a result of shifting the charging rate.

These concepts form the basis behind the presented energy control strategies, as discussed in more detail below.

B. Energy Control Strategies

We present two control strategies which differ in approach, complexity, requirements and results: a *local energy control strategy* and a *global energy control strategy*. Both strategies aim at minimizing peak load and flattening the overall load profile stemming from charging PHEVs. We will benchmark these energy control strategies against a business-as-usual (BAU) scenario in which we assume that charging starts upon plugging in the PHEV and happens at a constant rate until the vehicle is fully charged. There is no control or coordination in the BAU scenario. An overview of the control strategies is presented next.

1) *Local energy control strategy*: The first energy control strategy controls the charging process of each vehicle independently. A charging schedule is determined upon plugging in the vehicle, for which we also assume to know its planned departure time. The local energy control strategy will determine the times and charging rates at which the vehicle recharges its batteries based on the predicted local residential base load. This base load is made up from the individual loads from electric appliances which have no flexibility in their usage or power consumption and that are present in the home where the vehicle is charging. As a result the charging process is optimized locally but without considering the non-local impact: when considering the global electrical load over a whole residential area, global peaks can grow or new ones can be created.

2) *Global energy control strategy*: The second energy control strategy controls and coordinates the charging process of multiple vehicles within a residential area (typically comprising e.g. 100–200 houses). Similar to the local energy control strategy, the global strategy will also determine a charging schedule upon plugging in the vehicle, but in contrast to

the local strategy, the schedule will be based on global load information which is the aggregation of the loads at each home which includes load resulting from charging PHEVs. As a result the charging process is optimized globally over the complete residential area without considering the local impact: existing local peaks can grow or new ones can be created.

The energy control strategies have different requirements concerning infrastructure and communication, leading to the high-level architectures sketched in Fig. 2.

The business-as-usual scenario has no requirements besides basic charging infrastructure which needs a connection to the power grid. The *local* energy control strategy also requires a Home Energy Control Box (or Smart Charger) that is responsible for performing the local energy control strategy. The Home Energy Control Box needs to be able to determine the current and future local energy demand in order to determine the charging schedules. The *global* energy control strategy also requires a Home Energy Control Box, but since it needs to gather information on the global load profile of a residential area, it requires a connection with a communication network in order to determine for example the global load profiles. Depending on how we implement the global energy control strategy, communication needs to be possible with a coordinator and/or the other homes which are managed. The coordinator is an optional component and depends on the chosen implementation. Highly distributed approaches (e.g. using a pure peer-to-peer approach) will omit the coordinator while it is essential in centralized client-server architecture (where intelligence can be pushed into the network, and hence limit the need for management and maintenance of complex home energy boxes). Both approaches have their advantages and disadvantages; in this paper we will focus on quantifying the benefits in terms of electrical energy load profiles that a *global* control strategy could offer compared to a *local* one.

C. Methodology

In this section we will discuss the energy control strategies in detail. The local and global energy control strategies are both based on quadratic programming and aim to minimize the peak load and flatten the overall load profile. Hence, the optimal load profile in this context would be a constant or flat load profile, but this is unrealistic because we assume to have no control over the base load. Nevertheless we can try to approach this optimal load profile as best as possible. This is exactly what happens in the energy control strategies which we discuss in the following subsections. The strategies differ mainly in the way these optimal load profiles are determined.

1) *General*: The total duration for which base load information is provided is divided in intervals with an identical duration Δ (expressed in hours, typically 0.25h). The energy control strategies determine the charge rate for the successive intervals during which the vehicle is connected to the grid. Note we assume the departure time of the vehicle to be known (in practice this could be predicted based on historical data, or set by the user directly). We define the interval in which vehicle i arrives and is able to start charging as α_i and the

interval in which the vehicles leaves as β_i : the interval that can be used for charging vehicle i is are $[\alpha_i, \beta_i]$.

The capacity of the battery present in the PHEV is expressed in Wh and is represented by C_b^i . The amount of battery capacity still loaded upon arrival at home is represented by C_c^i , which we also assume to be known.

In addition, we assume that the connection to the power grid is bounded by a maximum load limit L_{max}^i .

As indicated previously, the proposed energy control strategies both require that the electrical loads within the home(s) during the time the vehicle is connected are known when determining the charging schedule. (In practice, this could be predictions based on historical data gathered by the Home Energy Control Box and possibly additional context information. This however is outside the scope of this paper.)

2) *Local energy control strategy*: The first step of the local energy control strategy is determining the optimal load profile which is based on the local base load and a fixed charger load. The optimal load profile in this context is a constant load profile which is characterized by a constant load $L_{o,l}^i$ (in Watts). The local base load in interval t is given by $L_{l,b}^i(t)$. The optimal load $L_{o,l}^i$ is determined by the following equations. Equation (1) determines the optimal local base load $L_{o,l,b}^i$, being the constant constant load profile (over interval $[\alpha_i, \beta_i]$ representing the same power consumption as the original (local) base load profile: it is the average of the original base load profile over $[\alpha_i, \beta_i]$.

$$L_{o,l,b}^i = \frac{1}{\beta_i - \alpha_i} \cdot \sum_{t=\alpha_i}^{\beta_i-1} L_{l,b}^i(t) \quad (1)$$

Equation (2) determines the fixed charger load $L_{o,c}^i$ which would fully charge the batteries during the available period.

$$L_{o,c}^i = \frac{C_b^i - C_c^i}{\beta_i - \alpha_i} \cdot \frac{1}{\Delta} \quad (2)$$

The fixed charger and optimal local base load are added together in equation (3) to form the constant optimal load $L_{o,l}^i$ of the optimal load profile.

$$L_{o,l}^i = L_{o,l,b}^i + L_{o,c}^i \quad (3)$$

Now that we know the fixed load $L_{o,l}^i$ of the optimal load profile, we can construct the objective function. Before we do so we have to define the real total load $L_1^i(t)$ during each interval, which is the sum of the local base load and the charger load $L_c^i(t)$ that is determined by minimizing the objective function.

$$L_1^i(t) = L_{l,b}^i(t) + L_c^i(t) \quad (4)$$

The charger loads $L_c^i(t)$ are the problem variables which have to be determined by minimizing the objective function. This objective function is given in equation (5) and aims at minimizing the difference between the optimal load $L_{o,l}^i$ and the real total load $L_1^i(t)$.

$$\min f = \sum_{t=\alpha_i}^{\beta_i-1} (L_{o,l}^i - L_1^i(t))^2 \quad (5)$$

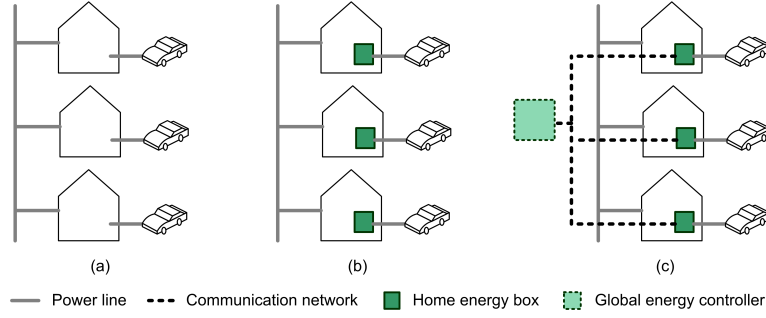

Fig. 2. Energy control architectures: (a) Business-as-usual (b) Local Energy Control (c) Iterative Global Energy Control

Next we define the constraints which will influence the result of the optimization:

$$L_1^i(t) \leq L_{max}^i \quad (6)$$

$$C_c^i + \sum_{t=\alpha}^{\beta-1} L_c^i(t) \cdot \Delta = C_b^i \quad (7)$$

Equation (6) states that the local load during each interval is limited to the maximum load supported by the connection to the power grid. The battery has to be fully charged when the vehicle departs, which is stated in equation (7).

3) *Global energy control strategy*: As a global energy control strategy, we evaluate an iterative extension of the local strategy, using a similar approach, but using the global load profile instead of the local load profile. The global energy control strategy is executed whenever a vehicle connects with the power grid in order to recharge its batteries. It is performed on a first-come-first-served base when multiple vehicles arrive during the same interval and the global base load information is updated after determining each schedule, hence the iterative nature of this strategy.

We start again by determining the optimal load profile which is based on the global load profile, instead of the local base load profile. The global load profile is the sum of all the local loads which consist of the local base loads $L_{l,b}^i(t)$ and charger loads $L_c^i(t)$ which are defined in charging schedules. The superscript i specifies the individual homes and vehicles when present. We assume there are k houses. The global load in interval t is given by $L_{g,b}^i(t)$ which is defined in equation (8).

$$L_{g,b}^i(t) = \sum_{j=1}^k (L_{l,b}^j(t) + L_c^j(t)) \quad (8)$$

The charger load $L_c^j(t)$ in equation 8 is equal to zero when no vehicle is connected at home j or the charging schedule for that home has not been determined yet (including the current home i).

The optimal global load $L_{o,g}^i$ is determined by the following equations. Equation (9) determines the optimal global base load $L_{o,g,b}^i$ in case a constant load profile would represent the

same power consumption as the original global load profile.

$$L_{o,g,b}^i = \frac{1}{\beta_i - \alpha_i} \cdot \sum_{t=\alpha_i}^{\beta_i-1} L_{g,b}^i(t) \quad (9)$$

The fixed charger load $L_{o,c}^i$ is determined by equation (2) which is also used in the local energy control strategy. The fixed charger and optimal global base load are added together in equation (10) to form the constant optimal load $L_{o,g}^i$.

$$L_{o,g}^i = L_{o,g,b}^i + L_{o,c}^i \quad (10)$$

$$L_2^i(t) = L_{g,b}^i(t) + L_c^i(t) \quad (11)$$

The objective function is given by equation (12).

$$\min f = \sum_{t=\alpha_i}^{\beta_i-1} (L_{o,g}^i - L_2^i(t))^2 \quad (12)$$

The constraints are:

$$L_{l,b}^i(t) + L_c^i(t) \leq L_{max}^i \quad (13)$$

$$C_c^i + \sum_{t=\alpha_i}^{\beta_i-1} L_c^i(t) \cdot \Delta = C_b^i \quad (14)$$

Equation (13) states that the local load at each home is limited to the maximum load supported by the connection to the power grid. The battery has to be fully charged when the vehicle departs, which is stated in equation (14).

III. CASE STUDY

To evaluate the PHEV charging control strategies, we developed a simulator framework based on OMNeT++ [5], where we model both the electrical distribution network and communication network in detail. The case study presented here provides quantitative results on the resulting electrical load profiles achieved by the proposed control strategies as well as the BAU scenario. We give an overview of the simulation parameters before discussing the results in detail.

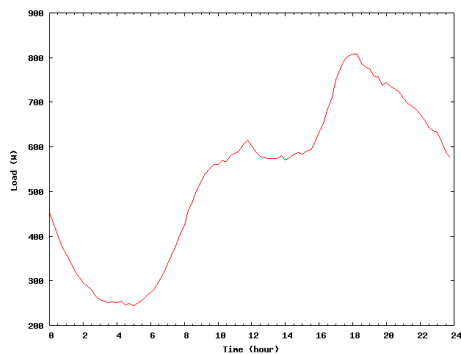

Fig. 3. Synthetic load profile.

Description	Characteristics
Battery type	Lithium-ion
Energy	16 kWh
Electric range	64 km

TABLE I
CHEVROLET VOLT SPECIFICATIONS [7]

A. Simulation parameters

This section presents quantitative simulation results over a set of 150 homes that simulate a feeder branch in an electrical distribution grid. Each home is characterized by a base load profile. The base load profile is based on synthetic load profiles which indicate the average power consumption of a home [6]. As explained, in this case study we assume that the energy control strategies have perfect knowledge about these load profiles. Figure 3 gives an example of a synthetic load profile for a period of 24 hours, starting at midnight. We have chosen two winter days where power consumption is high and examine the 24 hour period from 12:00 PM on day one to 12:00 PM on day two, as it provides a large amount of spare generating capacity. The power grid connection available in each home is based on Belgian standards which limits the maximum load to 9.2 kWh.

We based the model for the PHEVs on the specifications of the Chevrolet Volt which are shown in Table I [7]. We assumed the same specifications for every vehicle. The maximum charging rate is limited to 4.6 kWh which is half of the maximum allowed load and leaves room for other electrical appliances. The arrival and departure times vary between the vehicles and are based on a statistical availability model [8]. We consider three scenarios where respectively 10%, 30% and 60% of the homes has a PHEV. (Note: For Belgium, it has been forecasted that 30% of all vehicles will be PHEVs by 2030 [9].)

B. Simulation results

Figure 4 gives an overview of the obtained simulation results. For each PHEV penetration level the impact of the business-as-usual scenario and the local and global energy control strategies are shown in reference to the load profile

PHEVs (%)	Power Consumption \nearrow (%)
10%	+6%
30%	+31%
60%	+44%

TABLE II
ADDITIONAL POWER CONSUMPTION RESULTING FROM CHARGING PHEVs IN COMPARISON TO A SCENARIO WITHOUT PHEVs.

	P_{max} (kW)	P_{max} \searrow (%)
Business-as-usual		
10%	137	-
30%	197	-
60%	240	-
Local		
10%	127	8%
30%	146	26%
60%	149	38%
Global		
10%	126	8%
30%	137	30%
60%	139	42%

TABLE III
PEAK LOADS WHICH ARE THE RESULT FROM PERFORMING THE ENERGY CONTROL STRATEGIES. THE REDUCTION IN PEAK LOAD IS RELATIVE TO THE BUSINESS-AS-USUAL SCENARIO WITH CORRESPONDING PHEV PENETRATION.

resulting from when no PHEVs are present. We discuss the details of these results in the following paragraphs.

Charging PHEVs has a significant impact on the power consumption when we compare any of the scenarios which include PHEVs with the scenario without PHEVs. The additional power consumption ranges from 6% to 44% depending on the penetration grade of PHEVs. Table II gives an overview of the influence of PHEV penetration on additional power consumption.

The influence of the control strategies on the *peak load* is shown in table III. The business-as-usual scenario has the highest peak load which is 13%, 62% or 98% higher, depending on the number of PHEVs, than in the scenario without PHEVs. The local energy control strategy has the most significant impact on the peak load when compared to the business-as-usual scenario and the improvement ranges from 8% to 38%. The global energy control strategy lowers the peak load even further and results in an improvement ranging from 8% to 42%, but the improvement over the local energy control strategy is limited and ranges up to 4% extra. This suggests that adding smart grids functionality to the home in the form of a local Home Energy Control Box seems very promising. Whether it pays off to implement global control strategies—implying added cost of installing, maintaining and managing a communication network—is less clear, based solely on the effects on the global peak load levels by merely controlling PHEV charging.

The *flatness* of the overall load profiles is evaluated based on the standard deviations and variances which are calculated of the load levels over the time intervals in a 24h period, as shown in Table IV. The local and global energy control

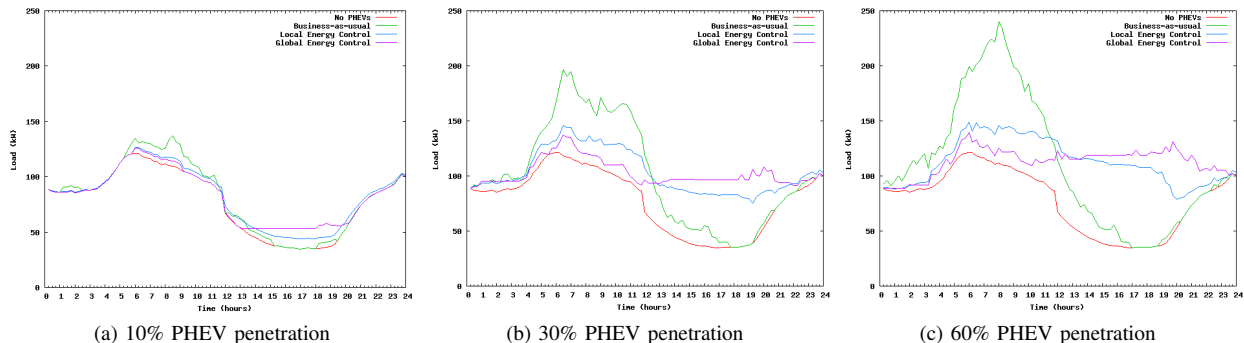

Fig. 4. Global load as a result of the energy control strategies.

	s	$s \searrow$	s^2	$s^2 \searrow$
Business-as-usual				
10%	31.70	-	1004.76	-
30%	46.69	-	2180.38	-
60%	58.50	-	3421.92	-
Local				
10%	26.41	17%	697.61	31%
30%	19.84	58%	393.69	82%
60%	20.30	65%	412.19	88%
Global				
10%	23.79	25%	565.89	44%
30%	11.55	75%	133.32	94%
60%	11.92	80%	142.07	96%

TABLE IV

STANDARD DEVIATIONS AND VARIANCES OVER THE LOAD PROFILES RESULTING FROM APPLYING THE DIFFERENT SCENARIOS AND CONTROL STRATEGIES.

strategy both improve the flatness of the load profile but the global energy control strategy results in the most optimal load profile. However the improvement of the global energy control strategy over the local energy control strategy is small in comparison to the improvement of the local energy control strategy over the business-as-usual scenario. The improvements grow when the penetration level of PHEVs rises which indicates that PHEVs are usefull resources for levelling the overall energy demand.

IV. CONCLUSION

Energy control strategies can lower peak load and flatten the overall load profile as a result of shifting energy demand and controlling the intensity of it. In this paper, we investigated the effect of such energy control mechanisms on the resulting electrical load stemming from PHEV adoption. As a benchmark we consider a business-as-usual (BAU) scenario without using any smart grid approach, where electrical vehicles are maximally charged immediately upon arrival and when plugged in. In this BAU scenario, a 30% PHEV penetration may lead to almost 1.5 times the peak load of current electricity consumption in a residential area. This peak can be significantly reduced (around -26% for 30% PHEV penetration) by a *local* control strategy, only relying on the electricity consumption information of the house a PHEV is attached to. A *global*

strategy, requiring data exchange between the homes (and/or possibly a controlling entity in the network), further reduces the peak load compared to BAU (with an additional -4%) and has clear advantages in flattening the load profile over time.

V. FUTURE WORK

Expanding these energy control strategies to other electric appliances which offer flexibility in their usage and power consumption could further optimize the overall load profile. Examples of devices which are possible candidates to be managed by energy control mechanisms are washing machines, heaters, refrigerators, lights, etc.

In our case study, we assumed the charging schedules (as determined by the energy control strategies) to have a granularity of 15 minutes, corresponding to the assumed granularity of the load information. Further research could investigate optimization of this granularity in terms of performance and data exchange requirements.

We assumed exact knowledge of the base load stemming from non-flexible appliances, as well as knowledge of the departure times of the PHEV. Further research is needed to devise real-time strategies capable of dealing with uncertainty and/or making intelligent prognoses of short-term energy consumption.

ACKNOWLEDGMENT

Work presented in this paper has been supported by the Flemish Government through the LINEAR project (through IWT) and the project SmartE (an IBBT ICON project). K. Mets would like to thank the Institute for the Promotion of Innovation by Science and Technology in Flanders (IWT) for financial support through his Ph. D. grant. C. Develder thanks the Research Foundation - Flanders (FWO - Vlaanderen) for his post-doctoral fellowship.

REFERENCES

- [1] S. W. Hadley, "Impact of Plug-in Hybrid Vehicles on the Electric Grid," Oak Ridge National Laboratory, Tech. Rep., October 2006. [Online]. Available: http://www.ornl.net/info/ornlreview/v40_2_07/2007_plug-in_paper.pdf

- [2] K. Clement, E. Haesen, and J. Driesen, "The Impact of Uncontrolled and Controlled Charging of Plug-in Hybrid Electric Vehicles on the Distribution Grid," in *EET-2008 3d European Ele-Drive Transportation Conference*, Geneva, Switzerland, March 2008. [Online]. Available: http://www.esat.kuleuven.be/electa/publications/fulltexts/pub_1767.pdf
- [3] T. Markel, M. Kuss, and P. Denholm, "Communication and Control of Electric Vehicles Supporting Renewables," in *IEEE Vehicle Power and Propulsion Systems Conference*, Dearborn, MI, USA, September 7-10 2009. [Online]. Available: <http://www.nrel.gov/vehiclesandfuels/vsa/pdfs/46224.pdf>
- [4] W. Kempton and J. Tomic, "Vehicle-to-grid power implementation: From stabilizing the grid to supporting large-scale renewable energy," *Journal of Power Sources*, vol. 144, pp. 280–294, 2005.
- [5] A. Varga, "An overview of the OMNeT++ simulation environment," in *Proc. 1st Int. Conf. Simulation Tools and Techniques for Commun., Netw. and Systems (SIMUTools)*, Marseille, France, 3–7 March 2008.
- [6] "Vlaamse reguleringsinstantie voor de elektriciteits- en gasmarkt (VREG)," <http://www.vreg.be>.
- [7] "Chevy volt website." [Online]. Available: <http://www.chevy-volt.net/chevrolet-volt-specs.htm>
- [8] E. D. Caluwé, "Potentieel van demand side management, piekvermogen en netondersteunende diensten geleverd door Plug-in Hybride Elektrische Voertuigen op basis van een beschikbaarheidsanalyse." Master's thesis, Katholieke Universiteit Leuven, 2007–2008.
- [9] S. Logghe, B. V. Herbruggen, and B. V. Zeebroeck, "Emissions of Road Traffic in Belgium," Transport & Mobility Leuven, Tech. Rep., January 2006.